

QH05, QH10, QH15, QH20, & QH30 Series

Specifications & Capacities				
Model	QH05	QH10	QH15	QH20
3-Point hitch	Category 1	Category 1	Category 1	Category 2
Maximum lift Capacity	At 24" (61.0 cm) back from implement's lower 3-point hitch pins. Implement hitch must match hitch category listed above.			
	700 lbs (317.5 kg)	2000 lbs (907.2 kg)	2000 lbs (907.2 kg)	3600 lbs (1632.9 kg)
Overall width	32 1/4" (81.9 cm)	32 5/8" (82.9 cm)	32 5/8" (82.9 cm)	40" (1.02 m)
Overall height	20 1/4" (51.4 cm)	21 3/4" (55.2 cm)	23 1/4" (59.1 cm)	23 5/8" (60.0 cm)
Overall length	7 3/8" (18.7 cm)	8" (20.3 cm)	9" (22.9 cm)	8 7/8" (22.5 cm)
Weight without floating top link	37 lbs (16.8 kg)	67 lbs (30.4 kg)	70 lbs (31.8 kg)	120 lbs (54.4 kg)
Top hitch	Stationary	Stationary	Adjustable	Stationary
Hitch pin lock	Automatic on implement's lower 3-point hitch pins			

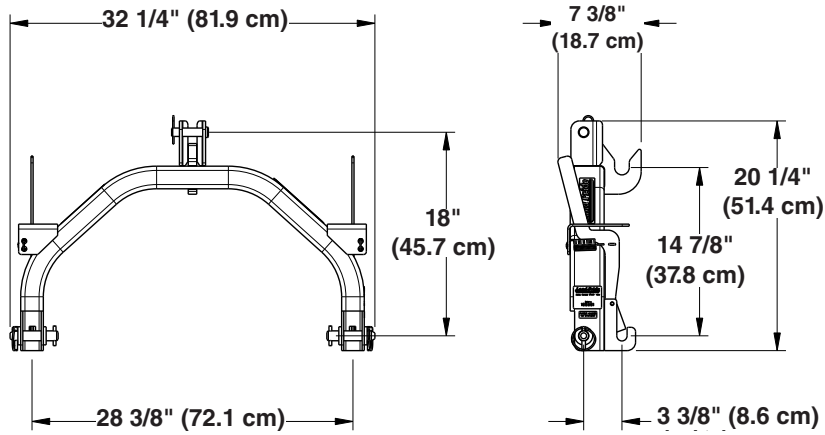

QH05 Quick Hitch  
Figure 5-1

37128

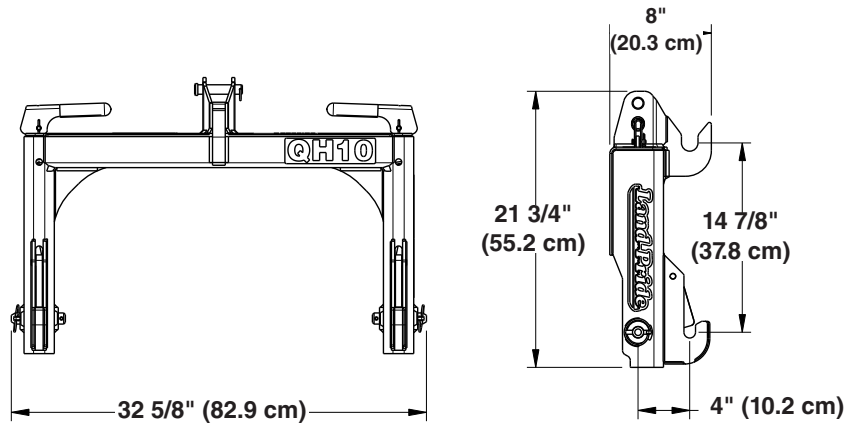

QH10 Quick Hitch  
Figure 5-2

70121

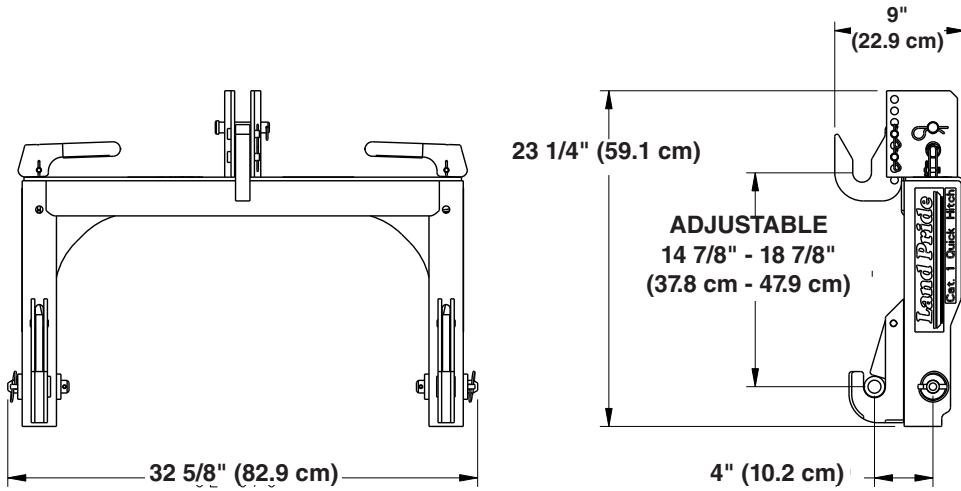

QH15 Quick Hitch  
Figure 5-3

26874

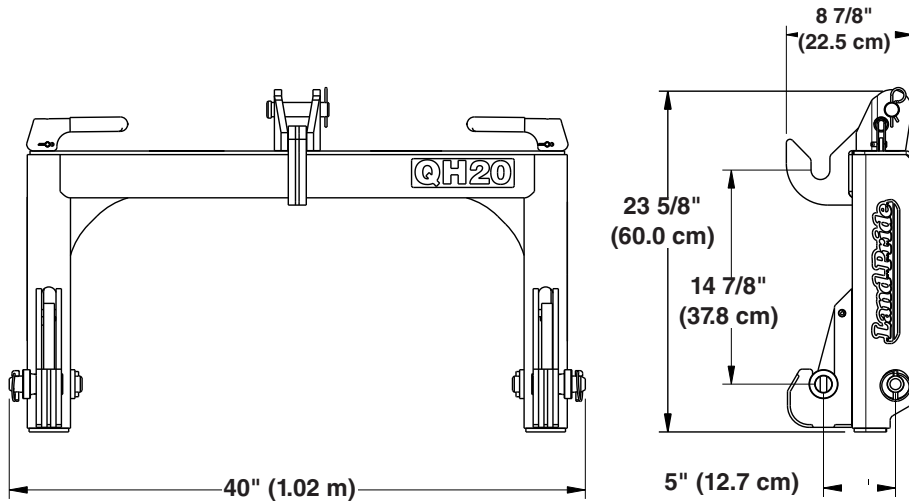

QH20 Quick Hitch  
Figure 5-4

24879

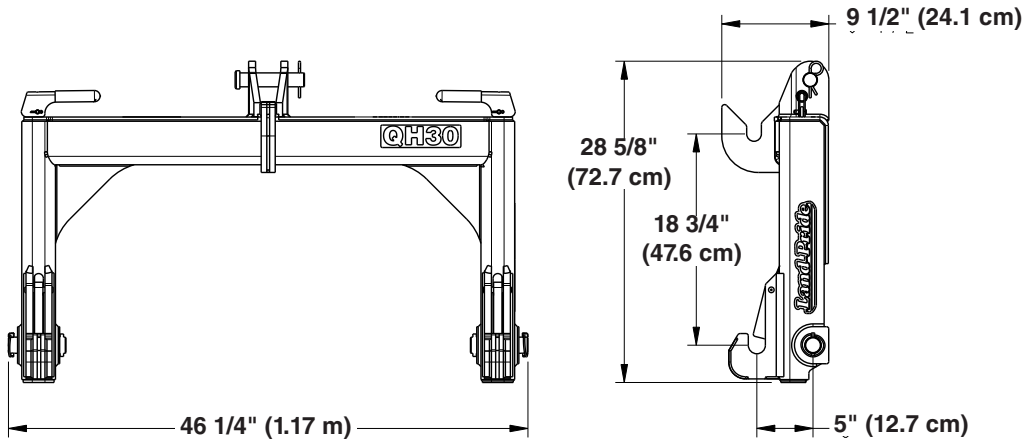

70315