

STIHL[®]

STIHL FS 45

Instruction Manual



Contents

Guide to Using this Manual	2
Safety Precautions and Working Techniques	2
Approved Combinations of Cutting Attachment, Deflector, Handle and Harness	9
Mounting the Loop Handle	10
Mounting the Deflector	11
Mounting the Cutting Attachment	11
Fuel	14
Fueling	15
Starting / Stopping the Engine	16
Operating Instructions	18
Cleaning the Air Filter	18
Adjusting the Carburetor	19
Spark Plug	21
Engine Running Behavior	22
Storing the Machine	22
Maintaining the Mowing Head	23
Inspections and Maintenance by Dealer	27
Maintenance and Care	28
Main Parts	30
Specifications	31
Maintenance and Repairs	32
Disposal	32
EC Declaration of Conformity	32

Dear Customer,

Thank you for choosing a quality engineered STIHL product.

It has been built using modern production techniques and comprehensive quality assurance. Every effort has been made to ensure your satisfaction and trouble-free use of the product.

Please contact your dealer or our sales company if you have any queries concerning this product.

Your



Dr. Nikolas Stihl



Guide to Using this Manual

Pictograms

The meanings of the pictograms attached to the machine are explained in this manual.

Depending on the model concerned, the following pictograms may be attached to your machine.



Fuel tank; fuel mixture of gasoline and engine oil

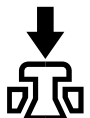

Operate decompression valve



Manual fuel pump

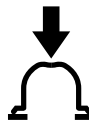

Operate manual fuel pump

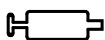

Tube of grease



Intake air: Summer operation



Intake air: Winter operation



Handle heating

Symbols in text



WARNING

Warning where there is a risk of an accident or personal injury or serious damage to property.



NOTICE

Caution where there is a risk of damaging the machine or its individual components.

Engineering improvements

STIHL's philosophy is to continually improve all of its products. For this reason we may modify the design, engineering and appearance of our products periodically.

Therefore, some changes, modifications and improvements may not be covered in this manual.

Safety Precautions and Working Techniques



Some special safety precautions must be observed to reduce the risk of personal injury when operating this power tool because of the very high speed of its cutting attachment.



It is important that you read the instruction manual before first use and keep it in a safe place for future reference. Non-observance of the instruction manual may result in serious or even fatal injury.

Observe all applicable local safety regulations, standards and ordinances.

If you have not used this type of power tool before: Have your dealer or other experienced user show you how to operate your unit or attend a special course in its operation.

Minors should never be allowed to use a power tool.

Keep bystanders, especially children, and animals away from the work area.

When the power tool is not in use, shut it off so that it does not endanger others. Secure it against unauthorized use.

The user is responsible for avoiding injury to third parties or damage to their property.

Do not lend or rent your power tool without the instruction manual. Be sure that anyone using it understands the information contained in this manual.

The use of noise emitting power tools may be restricted to certain times by national or local regulations.

To operate the power tool you must be rested, in good physical condition and mental health.

If you have any condition that might be aggravated by strenuous work, check with your doctor before operating a power tool.

Persons with pacemakers only: The ignition system of your power tool produces an electromagnetic field of a very low intensity. This field may interfere with some pacemakers. STIHL recommends that persons with pacemakers consult their physician and the pacemaker manufacturer to reduce any health risk.

Do not operate the power tool if you are under the influence of any substance (drugs, alcohol) which might impair vision, dexterity or judgment.

Depending on the cutting attachment fitted, use your trimmer only for cutting grass, wild growth and similar materials.

It must not be used for any other purpose because of the increased risk of accidents and damage to the machine. Never attempt to modify your power tool in any way since this may result in accidents or damage to the machine.

Only use cutting attachments and accessories that are explicitly approved for this power tool model by STIHL or are technically identical. If you have any

questions in this respect, consult a servicing dealer. Use only high quality tools and accessories. In order to avoid the risk of accidents and damage to the machine.

STIHL recommends the use of genuine STIHL tools and accessories. They are specifically designed to match the product and meet your performance requirements.

Never attempt to modify your unit in any way since this may increase the risk of personal injury. STIHL excludes all liability for personal injury and damage to property caused while using unauthorized attachments.

Do not use a pressure washer to clean the unit. The solid jet of water may damage parts of the unit.

The deflector on this power tool cannot protect the operator from all objects thrown by the cutting attachment (stones, glass, wire, etc.). Such objects may ricochet and then hit the operator.

Clothing and Equipment

Wear proper protective clothing and equipment.



Clothing must be sturdy but allow complete freedom of movement. Wear snug-fitting clothing, an overall and jacket combination, do not wear a work coat.



Avoid clothing that could get caught on branches or brush or moving parts of the machine. Do not wear a scarf, necktie or jewelry. Tie up and confine long hair (e.g. with a hair net, cap, hard hat, etc.).



Wear sturdy shoes with non-slip soles.



WARNING



To reduce the risk of eye injuries, wear snug-fitting safety glasses in accordance with European Standard EN 166. Make sure the safety glasses are a good fit.

Wear a face shield and make sure it is a good fit. A face shield alone does not provide adequate eye protection.

Wear hearing protection, e.g. earplugs or ear muffs.



Wear heavy-duty work gloves made of durable material (e.g. leather).

STIHL offers a comprehensive range of personal protective clothing and equipment.

Transporting the Power Tool

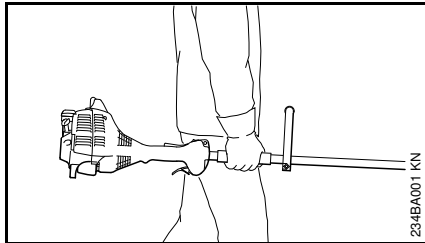

Always turn off the engine.

Carry the unit properly balanced by the drive tube or loop handle.

In vehicles: Properly secure your power tool to prevent turnover, fuel spillage and damage.

Fueling



Gasoline is an extremely flammable fuel. Keep clear of naked flames. Do not spill any fuel – do not smoke.

Always shut off the engine before refueling.

Do not fuel a hot engine – **fuel may spill and cause a fire.**

Open the fuel cap carefully to allow any pressure build-up in the tank to release slowly and avoid fuel spillage.

Fuel your power tool only in well-ventilated areas. If you spill fuel, wipe the machine immediately – if fuel gets on your clothing, change immediately.



After fueling, tighten down the fuel tank cap as securely as possible.

This reduces the risk of unit vibrations causing the fuel cap to loosen or come off and spill quantities of fuel.

To reduce the risk of serious or fatal burn injuries, check for fuel leakage. If fuel leakage is found, do not start or run the engine until leak is fixed.

Before Starting

Check that your power tool is properly assembled and in good condition – refer to appropriate chapters in the instruction manual.

- Check the fuel system for leaks, paying special attention to visible parts such as the tank cap, hose connections and the manual fuel pump (on machines so equipped). If there are any leaks or damage, do not start the engine – **risk of fire.** Have your machine repaired by a servicing dealer before using it again.
- Use only an approved combination of cutting attachment, deflector, handle and harness. All parts must be assembled properly and securely. To reduce the risk of injury, **never** use metal cutting attachments.
- Slide control / stop switch must move easily to **STOP** or **0**.

- Smooth action of throttle trigger lockout (if fitted) and throttle trigger – the throttle trigger must return automatically to the idle position.
- Check that the spark plug boot is secure – a loose boot may cause arcing that could ignite combustible fumes **and cause a fire.**
- Check cutting attachment for correct and secure assembly and good condition.
- Check protective devices (e.g. deflector for cutting attachment) for damage or wear. Always replace damaged parts. Never operate the unit with a damaged deflector.
- Never attempt to modify the controls or safety devices in any way.
- Keep the handles dry and clean – free from oil and dirt – for safe control of the power tool.
- Adjust the harness and handle(s) to suit your height and reach.

To reduce the risk of accidents, do not operate your power tool if it is damaged or not properly assembled.

If you use a shoulder strap or full harness: Practice removing and putting down the power tool as you would in an emergency. To avoid damage, do not throw the machine to the ground when practicing.

Starting the Engine

Start the engine at least 3 meters from the fueling spot, outdoors only.

Place the unit on firm ground in an open area. Make sure you have good balance and secure footing. Hold the unit securely. The cutting attachment must be clear of the ground and all other obstructions because it may begin to run when the engine starts.

Your power tool is a one-person unit. **To reduce the risk of injury** from thrown objects, do not allow other persons within a radius of 15 meters of your own position – even when starting.



To reduce the risk of injury, avoid contact with the cutting attachment.

Do not drop start the power tool – start the engine as described in the instruction manual.



Note that the cutting attachment continues to run for a short period after you let go of the throttle trigger – **flywheel effect**.

Check idle speed setting: The cutting attachment must not rotate when the engine is idling with the throttle trigger released.

To reduce the risk of fire, keep hot exhaust gases and hot muffler away from easily combustible materials (e.g. wood chips, bark, dry grass, fuel).

Holding and Controlling the Unit

Always hold the power tool firmly with both hands on the handles.

Make sure you always have good balance and secure footing.

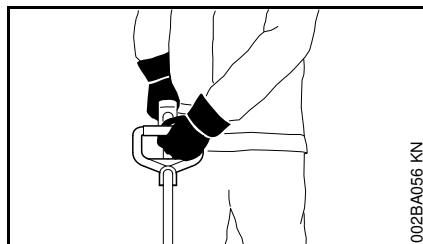

Left hand on loop handle, right hand on control handle, even if you are left-handed.

During Operation

In the event of impending danger or in an emergency, switch off the engine immediately by moving the slide control / stop switch to **STOP** or **0**.

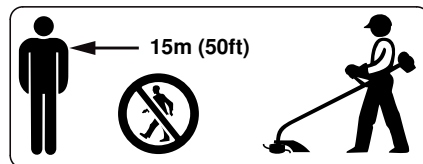

The cutting attachment may catch and fling objects a great distance and cause injury - therefore, do not allow any other persons within a radius of 15 meters of your own position. **To reduce the risk of damage to property**, also maintain this distance from other objects (vehicles, windows). Even maintaining a distance of 15 meters or more cannot exclude the potential danger.

The correct engine idle speed is important to ensure that the cutting attachment stops rotating when you let go of the throttle trigger.

Check and correct the idle speed setting regularly. If the cutting attachment continues to rotate when the engine is idling, have the machine checked by your servicing dealer.

Take special care in slippery conditions (ice, wet ground, snow), on slopes or uneven ground.

Watch out for obstacles: Roots, tree stumps or holes which **could cause you to trip or stumble**.

Make sure you always have good balance and secure footing.

Always stand on the ground while working, never on a ladder, work platform or any other insecure support.

Be particularly alert and cautious when wearing hearing protection because your ability to hear warnings (shouts, alarms, etc.) is restricted.

To reduce the risk of accidents, take a break in good time to avoid tiredness or exhaustion.

Work calmly and carefully – in daylight conditions and only when visibility is good. Stay alert so as not to endanger others.



Your power tool produces toxic exhaust fumes as soon as the engine is running. These fumes may be colorless and odorless and contain unburned hydrocarbons and benzol. Never run the engine indoors or in poorly ventilated locations, even if your model is equipped with a catalytic converter.

Ensure proper ventilation when working in trenches, hollows or other confined locations. **This reduces the risk of serious or fatal injury from breathing toxic fumes.**

To reduce the risk of accidents, stop work immediately in the event of nausea, headache, visual disturbances (e.g. reduced field of vision), problems with hearing, dizziness, deterioration in ability to concentrate. Apart from other possibilities, these symptoms may be caused by an excessively high concentration of exhaust gases in the work area.

Operate your power tool so that it produces a minimum of noise and emissions – do not run the engine unnecessarily, accelerate the engine only when working.

To reduce the risk of fire, do not smoke while operating or standing near your power tool. Note that combustible fuel vapor may escape from the fuel system.

The dusts, vapor and smoke produced during operation may be dangerous to health. If the work area is very dusty or smoky, wear a respirator.

If your power tool is subjected to unusually high loads for which it was not designed (e.g. heavy impact or a fall), always check that it is in good condition before continuing work – see also "Before Starting".

Check the fuel system in particular for leaks and make sure the safety devices are working properly. Do not continue operating your power tool if it is damaged. In case of doubt, consult your servicing dealer.

Do not operate your power tool in the starting throttle position – engine speed cannot be controlled in this position.



To reduce the risk of injury from thrown objects, never operate the power tool without the proper deflector for the type of cutting attachment being used.



Inspect the work area: Stones, pieces of metal or other solid objects may be thrown more than 15 meters and **cause personal injury** or damage the cutting attachment and property (e.g. parked vehicles, windows).

Special care must be taken when working in difficult, over-grown terrain.

When cutting high scrub, under bushes and hedges: Keep cutting attachment at a minimum height of 15 cm to avoid harming small animals.

Before leaving the power tool unattended: Shut off the engine.

Check the cutting attachment at regular short intervals during operation or immediately if there is a noticeable change in cutting behavior:

- Turn off the engine. Hold the unit firmly and press the cutting attachment into the ground to bring it to a standstill.
- Check condition and tightness, look for cracks.
- Replace damaged cutting attachments immediately, even if they have only superficial cracks.

Clean grass and plant residue off the cutting attachment mounting at regular intervals – remove any build up of material from the cutting attachment and deflector.

To reduce the risk of injury, shut off the engine before replacing the cutting attachment.

Do not continue using or attempt to repair damaged or cracked cutting attachments by welding, straightening or modifying the shape (out of balance).

This may cause parts of the cutting attachment to come off and hit the operator or bystanders at high speed and **result in serious or fatal injuries.**

When using mowing heads

Use only the deflector with properly mounted line limiting blade to ensure the mowing lines are automatically trimmed to the approved length.

To reduce the risk of injury, always turn off the engine before adjusting the nylon line of manually adjustable mowing heads

Using the unit with over-long nylon cutting lines reduces the engine's operating speed. The clutch then slips continuously and this causes overheating and damage to important components (e.g. clutch, polymer housing components) – **and this can increase the risk of injury** from the cutting attachment rotating while the engine is idling.

Vibrations

Prolonged use of the power tool may result in vibration-induced circulation problems in the hands (whitefinger disease).

No general recommendation can be given for the length of usage because it depends on several factors.

The period of usage is prolonged by:

- Hand protection (wearing warm gloves)
- Work breaks

The period of usage is shortened by:

- Any personal tendency to suffer from poor circulation (symptoms: frequently cold fingers, tingling sensations).
- Low outside temperatures.
- The force with which the handles are held (a tight grip restricts circulation).

Continual and regular users should monitor closely the condition of their hands and fingers. If any of the above symptoms appear (e.g. tingling sensation in fingers), seek medical advice.

Maintenance and Repairs

Service the machine regularly. Do not attempt any maintenance or repair work not described in the instruction manual. Have all other work performed by a servicing dealer.

STIHL recommends that you have servicing and repair work carried out exclusively by an authorized STIHL servicing dealer. STIHL dealers are regularly given the opportunity to attend training courses and are supplied with the necessary technical information.

Only use high-quality replacement parts in order to avoid the risk of accidents and damage to the machine. If you have any questions in this respect, consult a servicing dealer.

STIHL recommends the use of original STIHL replacement parts. They are specifically designed to match your model and meet your performance requirements.

To reduce the risk of injury, **always shut off the engine** before carrying out any maintenance or repairs or cleaning the machine. – Exception: Carburetor and idle speed adjustments.

Do not turn the engine over on the starter with the spark plug boot or spark plug removed unless the slide control /

stop switch is on **STOP** or **0** since there is otherwise a **risk of fire** from uncontained sparking.

To reduce the **risk of fire**, do not service or store your machine near open flames.

Check the fuel filler cap for leaks at regular intervals.

Use only a spark plug of the type approved by STIHL and make sure it is in good condition – see "Specifications".

Inspect the ignition lead (insulation in good condition, secure connection).

Check the condition of the muffler.

To reduce the **risk of fire and damage to hearing**, do not operate your machine if the muffler is damaged or missing. –

Do not touch a hot muffler since **burn injury** will result.

Cutting Attachments and Deflectors

For safety reasons only the combinations of cutting attachment, deflector, handle and shoulder strap approved in the model-specific instruction manual may be used.

Only mowing heads may be used on trimmers with a curved drive tube and loop handle.

Symbols on Deflectors

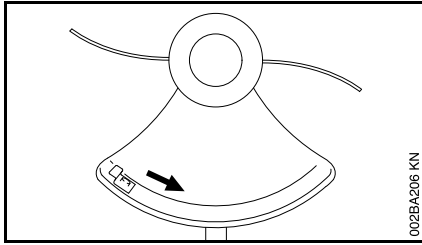

An arrow shows the direction of rotation of the cutting attachments.

Mowing Head with Nylon Lines

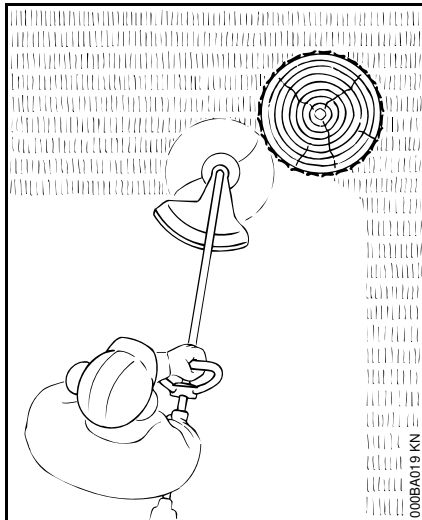

Nylon line achieves a soft cut for edging and trimming around fence posts, trees, etc. – less risk of damaging tree bark.

! WARNING

To reduce the **risk of injury**, **never** use steel wire in place of the nylon cutting line.

STIHL PolyCut 6-3 Mowing Head with Polymer Blades

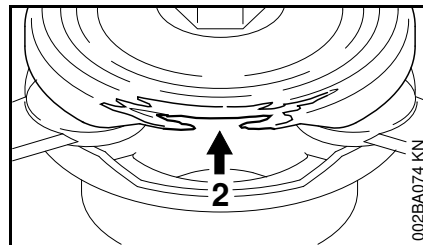
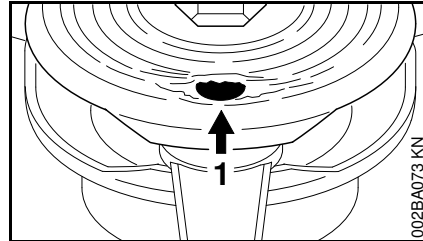

For mowing unobstructed edges of meadows (without posts, fences, trees or similar obstacles).

It is important to follow the maintenance instructions for the Polycut mowing head.

Check the wear limit marks!

Wear limit marks are integrated in the base of the PolyCut.

Do not continue using the PolyCut 6-3 if one of the circular holes (1; arrow) becomes visible or if the projecting rim (2; arrow) has worn away. Install a new mowing head.



! WARNING

If the wear limit marks are ignored, there is a risk of the cutting tool shattering and flying parts injuring the operator or bystanders.

To reduce the risk of accidents from shattered blades, avoid contact with stones, metal and similar solid objects.

Check PolyCut blades for cracks at regular intervals. If a crack is found in one of the blades, always replace **all** the blades.

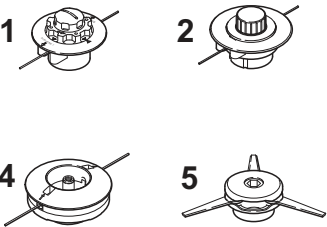
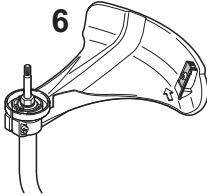
Approved Combinations of Cutting Attachment, Deflector, Handle and Harness

Cutting Attachment	Deflector	Handle	Harness
			

0000-GXX-0401-A3

Approved Combinations

Select correct combination from the table according to the cutting attachment you intend to use.

WARNING

For safety reasons no other combinations are permitted – **risk of accidents.**

Cutting Attachments

Mowing heads

- 1 STIHL AutoCut C 5-2
- 2 STIHL AutoCut 5-2
- 3 STIHL AutoCut C 6-2
- 4 STIHL DuroCut 5-2
- 5 STIHL PolyCut 6-3

Deflector

- 6 Deflector with blade, for mowing heads

Handle

- 7 Loop handle

Shoulder strap

- 8 Shoulder strap may be used

Mounting the Loop Handle

The loop handle comes in two different versions.

Version A

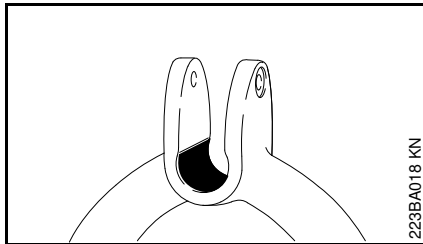
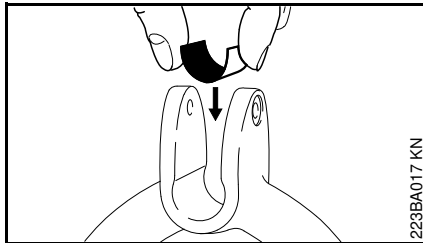

- Place the friction liner in the loop handle.

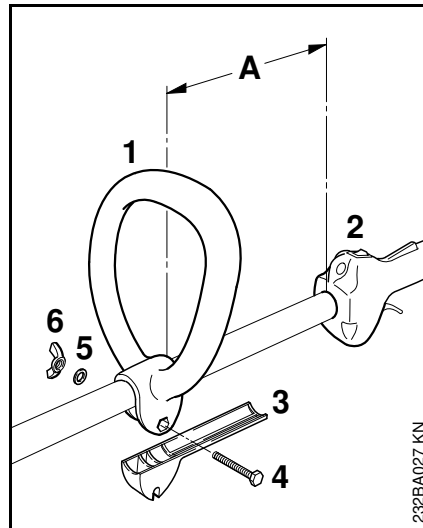

- Fit the loop handle (1) on the drive tube at distance (A) of about 20 cm (8 in.) from the control handle (2).
- Slide the spacer (3) – if supplied – into the loop handle as far as stop.
- Insert the screw (4) through the loop handle and the spacer until the screw head locates in the loop handle's hexagon recess.
- Fit the washer (5).
- Screw on the star knob (6) and tighten it down firmly.

Adjusting loop handle to most comfortable position

- Loosen the star knob (6).
- Move the loop handle (1) along the drive tube as required.
- Tighten down the star knob (6) firmly.

Version B

Your new power tool comes with the loop handle mounted on the drive tube, but it must be turned and lined up to suit your requirements.

Line up the loop handle.

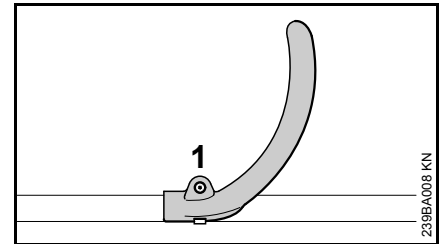

- Use the combination wrench to loosen the screw (1).

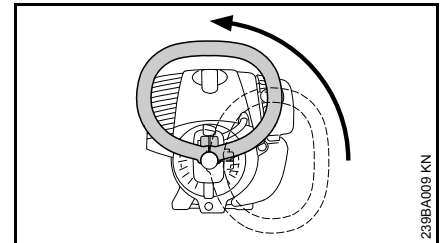

- Turn the handle to the vertical position.

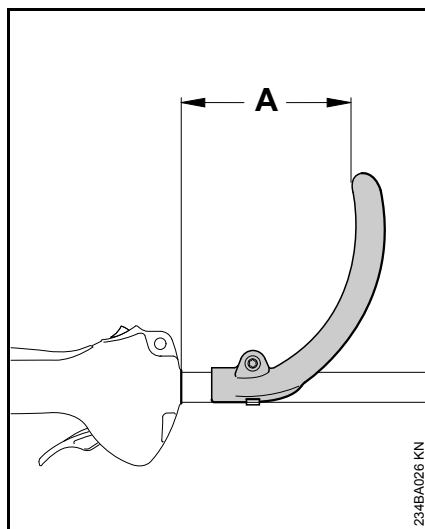

The loop handle can be adjusted to suit the height and reach of the operator and the application by changing distance (A).

Recommendation: distance (A): about 15 cm (6 in)

- Slide the handle to the required position.
- Tighten down the screw with the combination wrench so that the handle cannot be rotated on the drive tube.

Mounting the Deflector

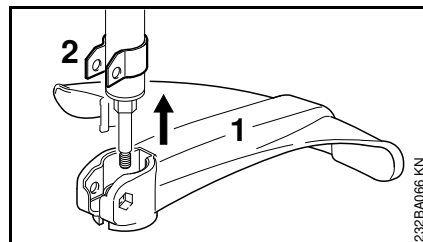

- Push the deflector (1) over the clamp (2) as far as stop.

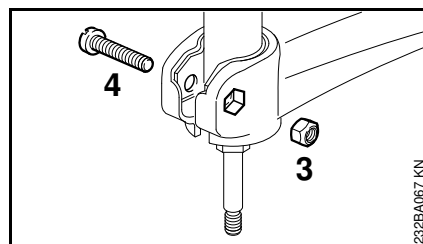

- Insert the nut (3) in the hex recess in the deflector – make sure the holes line up.
- Insert the screw (4) and tighten it down firmly.

Mounting the Cutting Attachment

Placing power tool on the ground

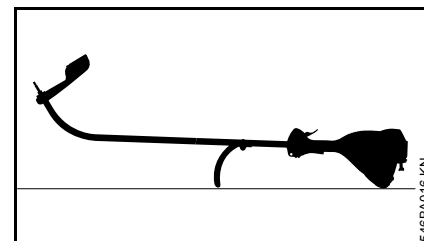

- Switch off the engine.
- Lay your trimmer on its back with the loop handle and shroud pointing down and the output shaft facing up.

Thrust Plate

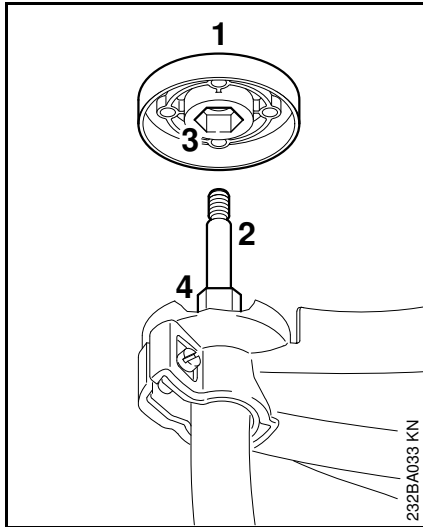

The thrust plate (1) is shipped with the DuroCut 5-2 and PolyCut 6-3. It is only required for these mowing heads.

STIHL AutoCut 5-2 mowing head, STIHL AutoCut C 5-2 mowing head

- Pull the thrust plate (1), if fitted, off the shaft (2).

STIHL PolyCut 5-2 mowing head, STIHL FixCut 6-3 mowing head

- Slip the thrust plate (1) over the shaft (2) and engage the hex recess (3) on the external hexagon (4).

Blocking the Shaft

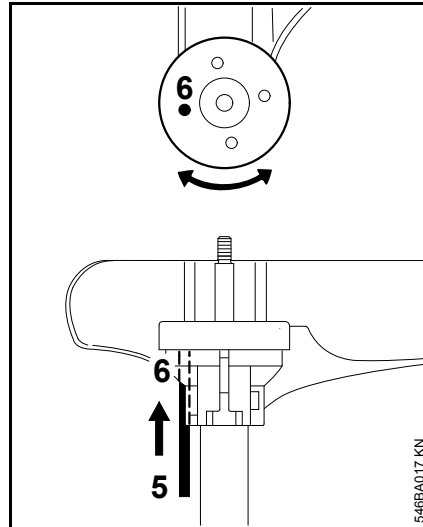

- To block the shaft, insert a suitable tool (5) through the holes (6) in the deflector and thrust plate – turn the thrust plate back and forth if necessary.

Fitting Mowing Head with Screw Mounting

Keep the instruction leaflet for the mowing head in a safe place.

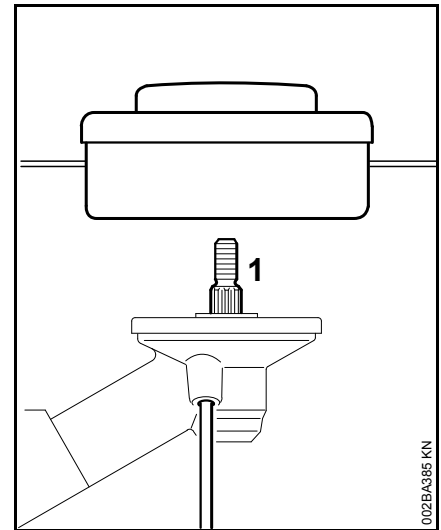

- Screw the mowing head counterclockwise on to the shaft (1) as far as stop.
- Block the shaft.
- Tighten down the mowing head firmly.



NOTICE

Remove the tool used to block the shaft.

Removing the Mowing Head

- Block the shaft.
- Unscrew the mowing head counterclockwise.

Fitting Mowing Head without Screw Mounting

Keep the instruction leaflet for the mowing head in a safe place.

STIHL AutoCut 5-2

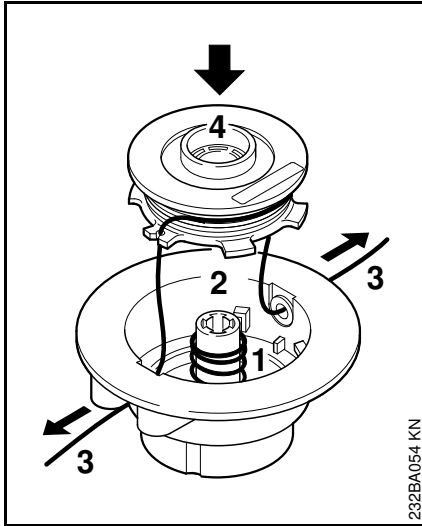

- Fit the spring (1) in the mowing head (2).
- Wind the mowing line (3) on to the spool (4).
- Thread the nylon line through the sleeves and fit the spool in the head.

The individual steps are described in the instruction sheet supplied.

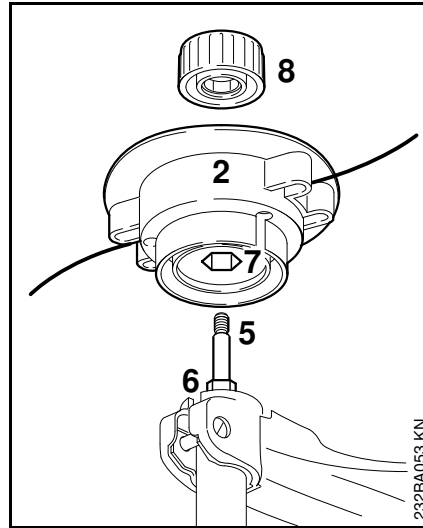

- Slip the mowing head (2) over the shaft (5) and engage hex recess (7) on the external hexagon (6).
- Fit the cap (8) on the mowing head – screw it clockwise on to the shaft as far as stop and tighten it down firmly.

STIHL AutoCut C 5-2

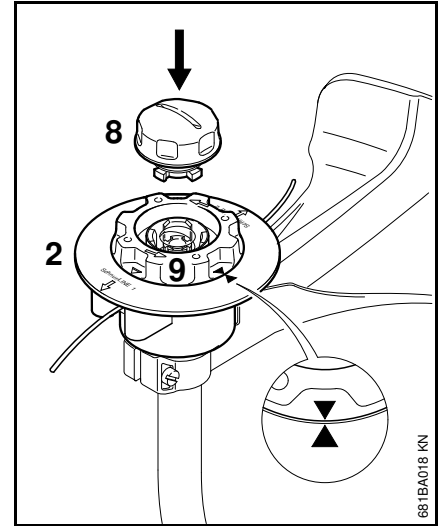

- Slip the mowing head (2) on to the shaft – as AutoCut 5-2.
- Turn the spool (9) clockwise until the two arrow heads line up – secure the spool in this position.
- Insert the cap (8) in the spool, press it down as far as stop and turn it clockwise at the same time.
- Turn the cap until you feel resistance and then tighten it down firmly by hand.

STIHL PolyCut 6-3

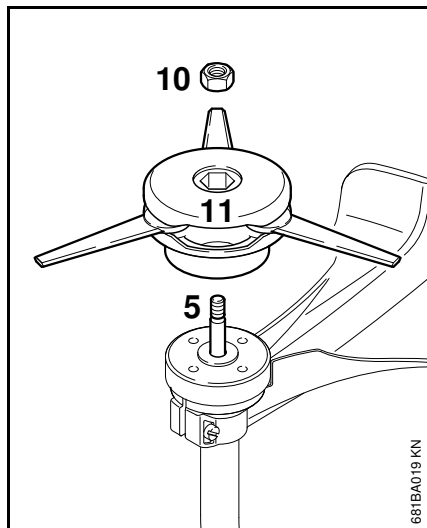

- Fit the thrust plate on the shaft.
- Insert the nut (10) in the mowing head.
- Screw the mowing head (11) clockwise on to the shaft (5) as far as stop.
- Block the shaft.
- Tighten down the mowing head firmly.

WARNING

If the mounting nut has become too loose, fit a new one.

NOTICE

Remove the tool used to block the shaft.

Remove the mowing head.

STIHL AutoCut

- Hold the mowing head steady.
- Unscrew the cap counterclockwise.

STIHL PolyCut

- Block the shaft.
- Unscrew the mowing head counterclockwise.

Fuel

Your engine requires a mixture of gasoline and engine oil.

WARNING

For health reasons, avoid direct skin contact with gasoline and avoid inhaling gasoline vapor.

STIHL MotoMix

STIHL recommends the use of STIHL MotoMix. This ready-to-use fuel mix contains no benzol or lead, has a high octane rating and ensures that you always use the right mix ratio.

STIHL MotoMix uses STIHL HP Ultra two-stroke engine oil for an extra long engine life.

MotoMix is not available in all markets.

Mixing Fuel

NOTICE

Unsuitable fuels or lubricants or mix ratios other than those specified may result in serious damage to the engine. Poor quality gasoline or engine oil may damage the engine, sealing rings, hoses and the fuel tank.

Gasoline

Use only high-quality **brand-name** gasoline with a minimum octane rating of 90 – leaded or unleaded.

Gasoline with an ethanol content of more than 10% can cause running problems in engines with a manually adjustable carburetor and should not be used in such engines.

Engines equipped with M-Tronic deliver full power when run on gasoline with an ethanol content of up to 25% (E25).

Engine Oil

If you mix the fuel yourself, use only STIHL two-stroke engine oil or another high-performance engine oil in accordance with JASO FB, JASO FC, JASO FD, ISO-L-EGB, ISO-L-EGC or ISO-L-EGD.

STIHL specifies STIHL HP Ultra two-stroke engine oil or an equivalent high-performance engine oil in order to maintain emission limits over the machine's service life.

Mix Ratio

STIHL 50:1 two-stroke engine oil: 50 parts gasoline to 1 part oil

Examples

Gasoline Liters	STIHL engine oil 50:1 Liters (ml)	
1	0.02	(20)
5	0.10	(100)
10	0.20	(200)
15	0.30	(300)
20	0.40	(400)
25	0.50	(500)

- Use a canister approved for storing fuel. Pour oil into canister first, then add gasoline and mix thoroughly.

Storing Fuel

Store fuel only in approved safety-type fuel canisters in a dry, cool and safe location protected from light and the sun.

Fuel mix ages – only mix sufficient fuel for a few weeks work. Do not store fuel mix for longer than 30 days. Exposure to light, the sun, low or high temperatures can quickly make the fuel mix unusable.

STIHL MotoMix may be stored for up to 2 years without any problems.

- Thoroughly shake the mixture in the canister before fueling your machine.

WARNING

Pressure may build up in the canister – open it carefully.

- Clean the fuel tank and canister from time to time.

Dispose of remaining fuel and cleaning fluid properly in accordance with local regulations and environmental requirements.

Fueling

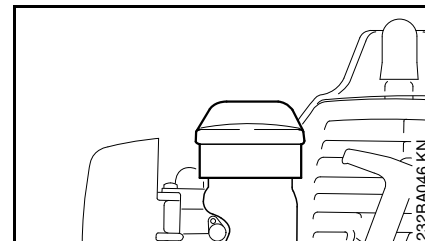

- Before fueling, clean the filler cap and the area around it to ensure that no dirt falls into the tank.
- Position the machine so that the filler cap is facing up.
- Open the filler cap.

Take care not to spill fuel while fueling and do not overfill the tank. STIHL recommends you use the STIHL filler nozzle (special accessory).

WARNING

After fueling, tighten down the filler cap as securely as possible by hand.

Starting / Stopping the Engine

Controls

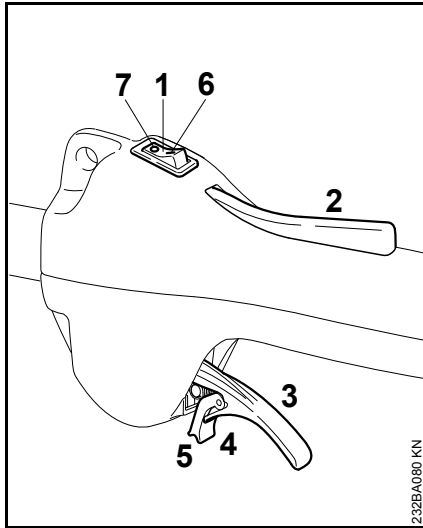

- 1 Stop switch
- 2 Throttle trigger lockout
- 3 Throttle trigger
- 4 Tongue of throttle trigger
- 5 Catch

Positions of stop switch

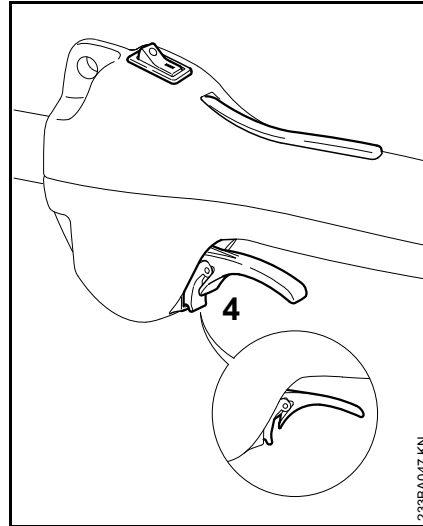

- 6 Run I
- 7 Stop 0

Starting

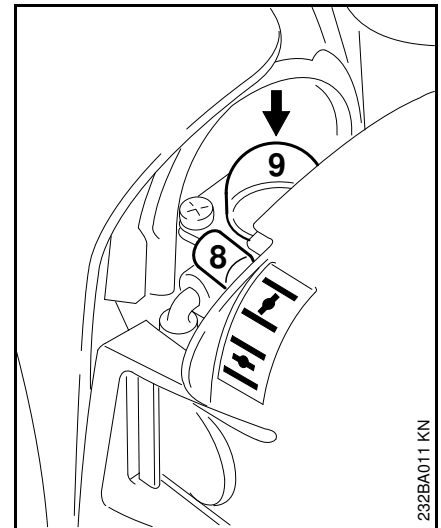

- Move the stop switch to I.
- Press down the throttle trigger lockout and hold it there.
- Squeeze the throttle trigger until the catch on the tongue (4) can be engaged on the housing (arrow).
- Now release the throttle trigger, tongue and trigger lockout in that order. This is the **starting throttle position**.



- Set the choke lever (8) to
 -  if the engine is cold
 -  for warm start – also use this position if the engine has been running but is still cold.
- Press the manual fuel pump bulb (9) at least five times – even if the bulb is filled with fuel.

Cranking

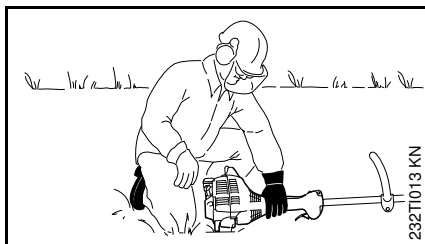
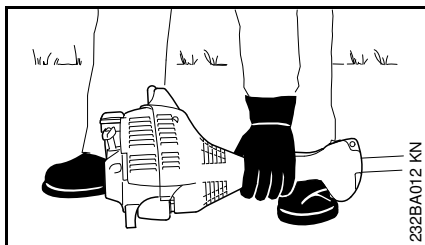

- Put the unit on the ground: It must rest securely on the engine support and the deflector. Check that the cutting attachment is not touching the ground or any other obstacles.
- Make sure you have a firm footing.
- Hold the unit with your left hand and press it down **firmly** – your thumb should be under the fan housing.



NOTICE

Do not stand or kneel on the drive tube.

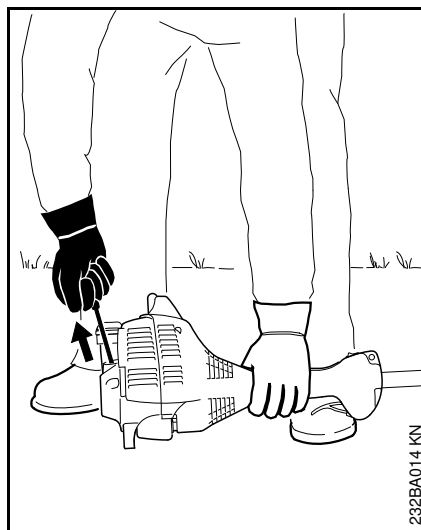

- Hold the starter grip with your right hand.

Version without ErgoStart

- Pull the starter grip slowly until you feel it engage and then give it a brisk strong pull.



NOTICE

Do not pull out the starter rope all the way – **it might otherwise break.**

Version with ErgoStart

- Pull the starter grip slowly until you feel it engage and then pull it out slowly and steadily.



NOTICE

Do not pull out the starter rope all the way – **it might otherwise break.**

Both versions

- Do not let the starter grip snap back. Guide it slowly back into the housing so that the starter rope can rewind properly.
- Continue cranking.

When engine begins to fire

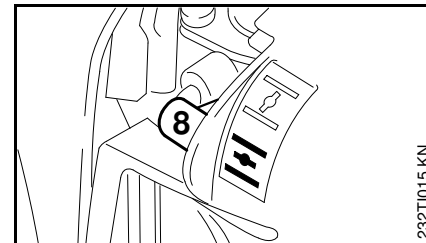

- After no more than **five** pulls, move the choke lever (8) to  and
- continue cranking.

As soon as the engine runs

- Squeeze the throttle trigger to disengage the tongue – the engine will settle down to idle speed.



WARNING

Make sure the carburetor is correctly adjusted. The cutting attachment must not rotate when the engine is idling.

Your machine is now ready for operation.

Stopping the engine

- Move the stop switch to **0**.

If engine does not start

Choke lever

If you did not move the choke lever quickly enough to  after the engine began to fire, the engine is flooded.

- Set choke to  and
- Move the stop switch to I, interlock lever and throttle trigger to the starting throttle position.
- Start the engine by pulling the starter rope briskly – 10 to 20 pulls may be necessary.

If the engine still does not start

- Move the stop switch to 0.
- Remove the spark plug – see "Spark Plug".
- Dry the spark plug.
- Crank the engine several times with the starter to clear the combustion chamber.
- Refit the spark plug – see "Spark Plug".
- Move the stop switch to I.
- Set choke to  – even if the engine is cold.
- Now start the engine.

Fuel tank run until completely dry

- After refueling, press the manual fuel pump bulb at least five times – even if the bulb is filled with fuel.
- Set the choke knob to suit the engine temperature.
- Start the engine.

Operating Instructions

During break-in period

A factory-new machine should not be run at high revs (full throttle off load) for the first three tank fillings. This avoids unnecessary high loads during the break-in period. As all moving parts have to bed in during the break-in period, the frictional resistances in the engine are greater during this period. The engine develops its maximum power after about 5 to 15 tank fillings.

During Operation

After a long period of full throttle operation, allow the engine to run for a short while at idle speed so that engine heat can be dissipated by the flow of cooling air. This protects engine-mounted components (ignition, carburetor) from thermal overload.

After Finishing Work

Storing for a short period: Wait for the engine to cool down. Empty the fuel tank and keep the machine in a dry place, well away from sources of ignition, until you need it again. For longer out-of-service periods – see "Storing the Machine".

Cleaning the Air Filter

If there is a noticeable loss of engine power

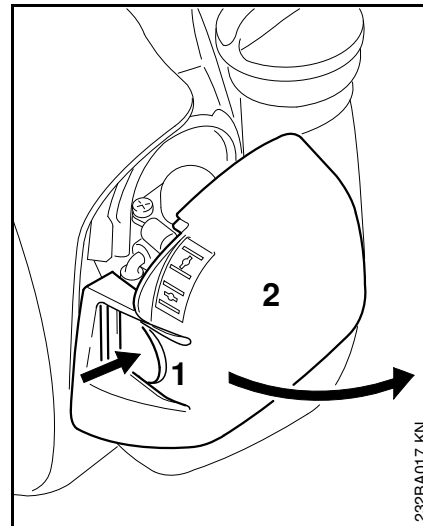

- Set the choke lever to .
- Press in the tab (1) and swing the filter cover (2) down.
- Clean away loose dirt from around the filter.

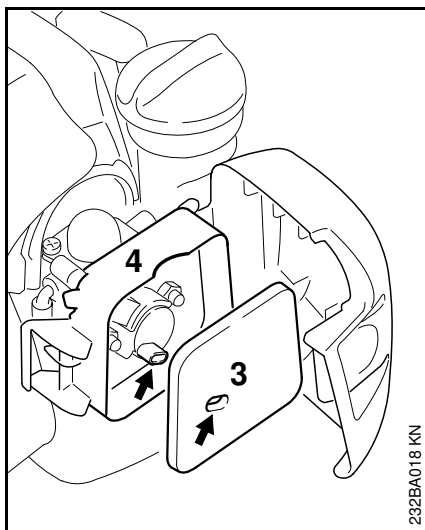

232BA018 KN

- Remove the felt element (3) from the filter housing (4) and replace it – knock out or blow out as a temporary measure – do not wash.
- Replace damaged parts.
- Fit the felt element (3) in the filter housing (4).
- Close the filter cover so that it snaps into position.

Adjusting the Carburetor

General Information

The carburetor comes from the factory with a standard setting.

This setting provides an optimum fuel-air mixture under most operating conditions.

Preparations

- Shut off the engine.
- Mount the cutting attachment.
- Check the air filter and clean or replace if necessary.
- Check the spark arresting screen in the muffler and clean or replace if necessary. STIHL recommends that you have servicing and repair work carried out exclusively by an authorized STIHL servicing dealer.

Different Standard Settings

Different carburetors are installed at the factory. A different standard setting is necessary for each of these carburetors.

Identifying the Carburetor

- Use the following illustrations to identify the carburetor installed in your machine and then adjust the carburetor as described:

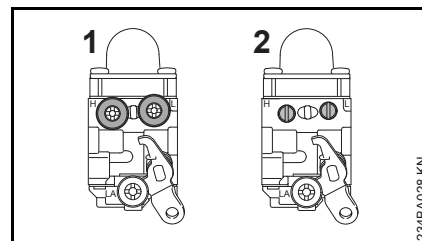

Carburetor 1

Carburetor with limiter caps on high speed screw (H) and low speed screw (L)

Carburetor 2

Carburetor without limiter caps on high speed screw (H) and low speed screw (L)

Standard Setting on Carburetor 1

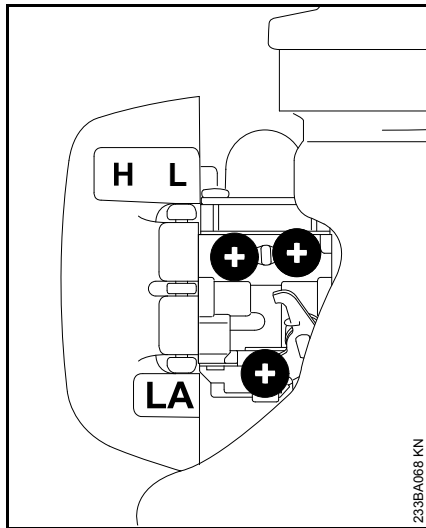

- Turn high speed screw (H) counterclockwise as far as stop (no more than 3/4 turn).
- Turn the low speed screw (L) carefully clockwise until it is against its seat, then it back it off a 3/4 turn.

Standard Setting on Carburetor 2

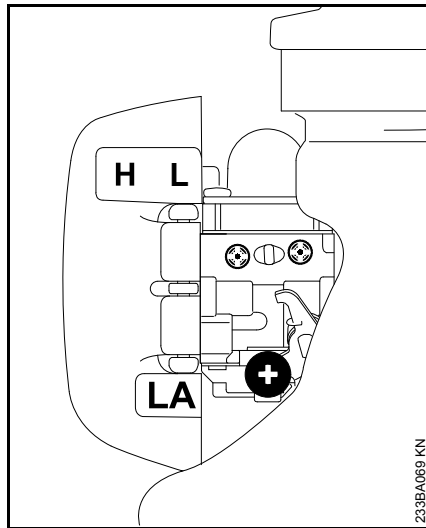

- Turn the low speed screw (L) carefully clockwise until it is against its seat, then turn it back 2 full turns.
- Turn the low speed screw (L) carefully clockwise until it is against its seat, then turn it back 1 1/2 turns.

Adjusting Idle Speed

- Carry out the standard setting.
- Start and warm up the engine.

Engine stops while idling

- Turn the idle speed screw (LA) slowly clockwise until the engine runs smoothly – the cutting attachment must not rotate.

Cutting attachment rotates when engine is idling

- Turn the idle speed screw (LA) counterclockwise until the cutting attachment stops moving and then turn the screw another 1/2 to 1 full turn in the same direction.

! WARNING

If the cutting attachment continues to rotate when the engine is idling, have your machine checked and repaired by your servicing dealer.

Erratic idling behavior, poor acceleration (despite correction to setting of LA screw).

Idle setting is too lean

Carburetor 1

- Turn the low speed screw (L) carefully counterclockwise, no further than stop, until the engine runs smoothly and still accelerates satisfactorily.

Carburetor 2

- Rotate the low speed screw (L) slowly about 1/4 turn counterclockwise until the engine runs smoothly and still accelerates satisfactorily.

Erratic idling behavior

Idle setting is too rich

Carburetor 1

- Turn the low speed screw (L) slowly clockwise, no further than stop, until the engine runs smoothly and still accelerates satisfactorily.

Carburetor 2

- Rotate the low speed screw (L) slowly about 1/4 turn clockwise until the engine runs smoothly and still accelerates satisfactorily.

It is usually necessary to change the setting of the idle speed screw (LA) after every correction to the low speed screw (L).

Fine Tuning for Operation at High Altitude

A slight correction of the setting may be necessary if engine does not run satisfactorily:

Carburetor 1

- Carry out the standard setting.
- Warm up the engine.
- Turn high speed screw (H) slightly clockwise (leaner) – no further than stop.

Carburetor 2

- Carry out the standard setting.
- Warm up the engine.
- Turn high speed screw (H) slightly clockwise (leaner) – no more than a 3/4 turn.



NOTICE

After returning from high altitude, reset the carburetor to the standard setting.

If the setting is too lean there is a risk of engine damage due to insufficient lubrication and overheating.

Spark Plug

- If the engine is down on power, difficult to start or runs poorly at idle speed, first check the spark plug.
- Fit a new spark plug after about 100 operating hours – or sooner if the electrodes are badly eroded. Install only suppressed spark plugs of the type approved by STIHL – see "Specifications".

Removing the Spark Plug

- Move the stop switch to 0.

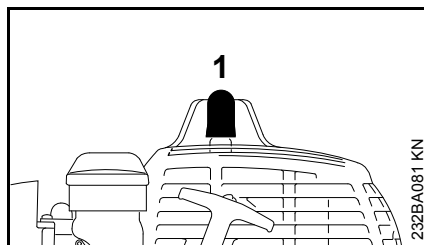

- Pull off the spark plug boot (1).
- Unscrew the spark plug.

Checking the Spark Plug

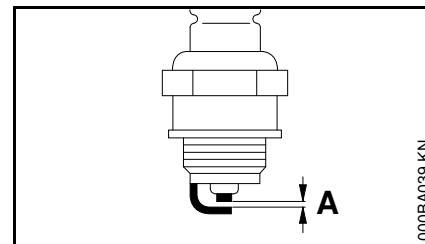

- Clean dirty spark plug.
- Check electrode gap (A) and readjust if necessary – see "Specifications".
- Rectify the problems which have caused fouling of the spark plug.

Possible causes are:

- Too much oil in fuel mix.
- Dirty air filter.
- Unfavorable running conditions.

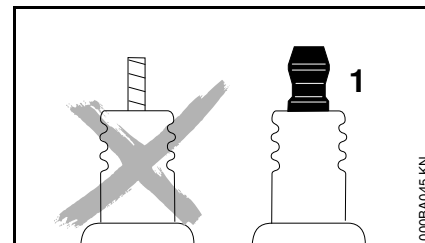

! WARNING

Arcing may occur if the adapter nut (1) is loose or missing. Working in an easily combustible or explosive atmosphere may cause a fire or an explosion. This can result result in serious injuries or damage to property.

- Use resistor type spark plugs with a properly tightened adapter nut.

Installing the spark plug

- Screw home the spark plug, fit the boot and press it down firmly.

Engine Running Behavior

If engine running behavior is unsatisfactory even though the air filter is clean and the carburetor is properly adjusted, the cause may be the muffler.

Have the muffler checked for contamination (carbonization) by your servicing dealer.

STIHL recommends that you have servicing and repair work carried out exclusively by an authorized STIHL servicing dealer.

Storing the Machine

For periods of about 3 months or longer

- Drain and clean the fuel tank in a well ventilated area.
- Dispose of fuel properly in accordance with local environmental requirements.
- Run the engine until the carburetor is dry – this helps prevent the carburetor diaphragms sticking together.
- Remove, clean and inspect the cutting attachment. Coat metal cutting attachments with corrosion inhibitor.
- Thoroughly clean the machine – pay special attention to the cylinder fins and air filter.
- Store the machine in a dry and secure location – out of the reach of children and other unauthorized persons.

Maintaining the Mowing Head

Placing power tool on the ground

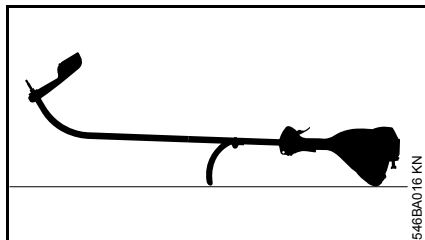

- Switch off the engine.
- Lay your trimmer on its back with the loop handle and shroud pointing down and the output shaft facing up.

Replacing Nylon Line

Always check the mowing head for signs of wear before replacing the nylon line.

! WARNING

If there are signs of serious wear, replace the complete mowing head.

The nylon mowing line is referred to as "nylon line" or "line" in the following.

The mowing head is supplied with illustrated instructions for replacing the nylon line. Keep the instructions for the mowing head in a safe place.

- If necessary, remove the mowing head.

Adjusting Nylon Line

STIHL AutoCut

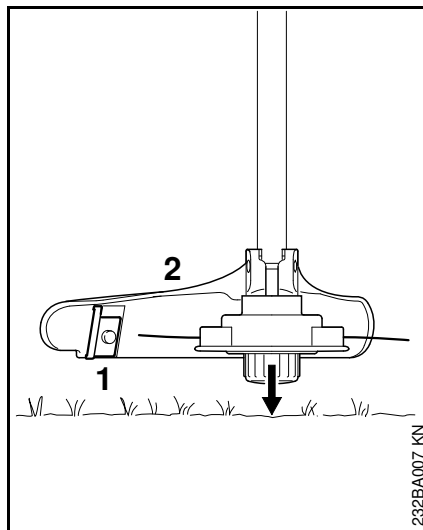

- Hold the rotating mowing head above the ground – tap it on the ground once – about 3 cm (1.2 in) of fresh line is advanced.
- The blade (1) on the deflector (2) trims surplus line to the correct length – avoid tapping the mowing head more than once at a time.

Line feed operates only if **both** lines still have a minimum length of **2.5 cm (1 in)**.

If the line is shorter than 2.5 cm (1 in):

! WARNING

To reduce the risk of injury, always shut off the engine before adjusting the nylon mowing line by hand.

- Turn the machine over.
- Press down the cap on the spool as far as stop.
- Pull the ends of the lines out of the spool.

If the spool is empty, refill with nylon line.

All other mowing heads

Refer to the leaflet supplied with the mowing head.

! WARNING

To reduce the risk of injury, always shut off the engine before adjusting the nylon mowing line by hand.

Replacing Nylon Line

STIHL DuroCut

! WARNING

To reduce the risk of injury, always shut off the engine before refilling the mowing head.

- Fit nylon line in the mowing head as described in the instructions supplied.

STIHL AutoCut C 5-2

Disassembling the mowing head and removing remaining nylon line

In normal operation, the supply of nylon line in the head is used up almost completely.

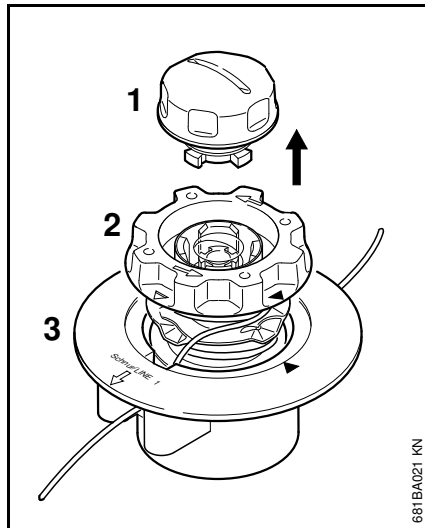

- Hold the mowing head steady and rotate the cap (1) counterclockwise until it can be removed.
- Pull the spool (2) out of the mowing head (3) and remove the remaining line.

Assembling the mowing head

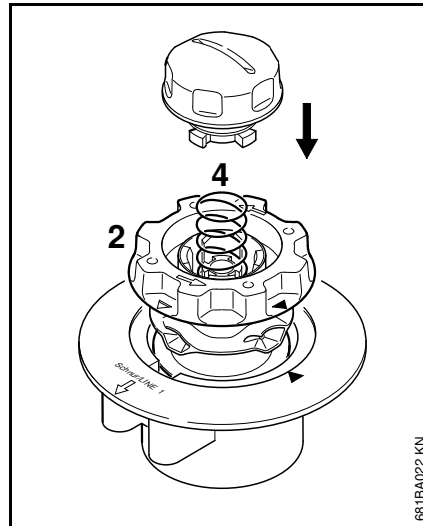

- Fit the **empty** spool in the mowing head.
- If the spring (4) has popped out:
- push it into the spool (2) until it engages in position with an audible click.
 - Mount the mowing head – see "Mounting the Mowing Head".

Winding line onto spool

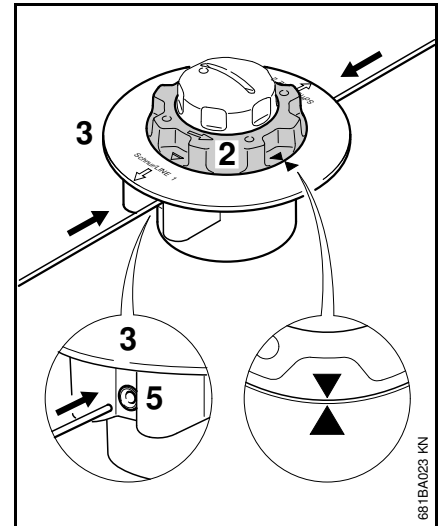

- Use green-coded nylon line with a diameter of 2.0 mm (0.08 in).
- Cut two 2 m (6ft 6in) lengths of nylon line from the reel (special accessory).
- Rotate the spool (2) counterclockwise until the two arrow points are in alignment.
- Push the **straight end of each line** through one sleeve (5) in the mowing head (3) until you feel a noticeable resistance – and then continue pushing as far as stop.

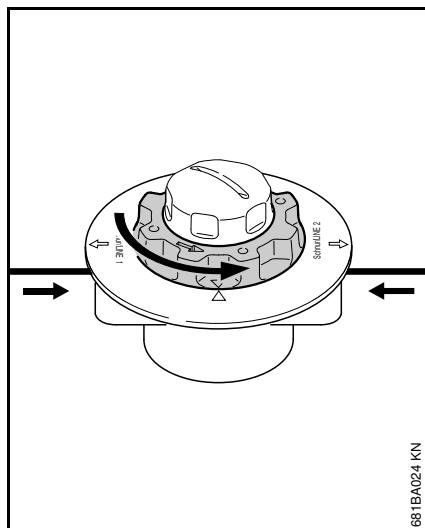

- Hold the mowing head steady.
- Rotate the spool counterclockwise until the shortest line is about 10 cm (4 in).
- If necessary, cut the longer line to a length of about 10 cm (4 in).

The mowing head is now full.

STIHL AutoCut 5-2

Removing remaining nylon line

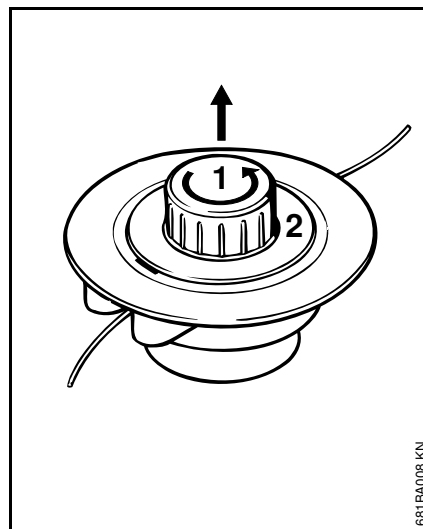

- Open the mowing head – hold it steady with one hand and turn the cap (1) counterclockwise.
- Disengage the spool (2), take it out of the mowing head and remove the remaining line.

Winding line onto spool

A prewound spool (special accessory) may be used as an alternative to the following procedure.

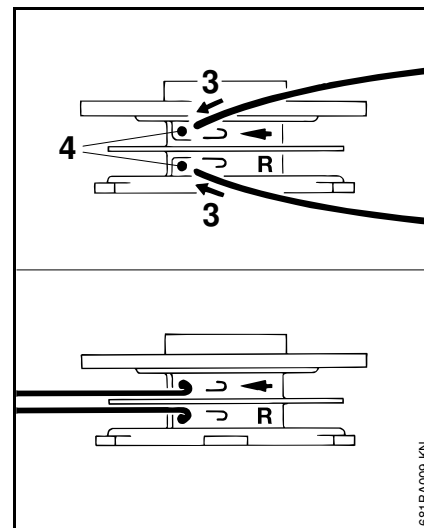

- Use green-coded nylon line with a diameter of 2.0 mm (0.08 in).
- Cut two 3 m (9ft 9in) lengths of nylon line from the reel (special accessory).
- Insert the ends of each line (3) in the holes (4) in the spool.
- Bend the ends of the lines over the edge of the holes to form a hook.

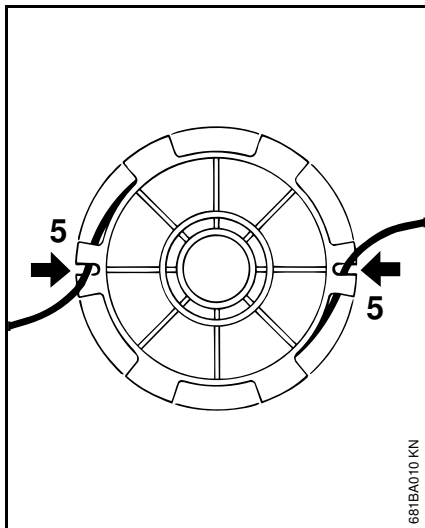

- Straighten out the nylon lines and wind them tightly on to the spool – one nylon line in each chamber.
- Engage the ends of the lines in the notches (2).

Assembling the mowing head



NOTICE

Check that the spring is installed (see "Mounting the Mowing Head").

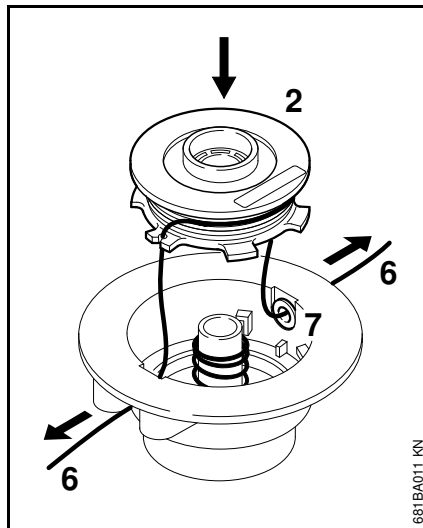

- Thread the ends of the lines (6) through the sleeves (7) and push the spool (2) into the head so that it snaps into position.

The nylon lines must disengage from the notches (5) as the spool is pushed into position.

- Pull out the ends of the lines as far as stop.
- Mount the mowing head on the machine.

Replacing Cutting Blades

STIHL PolyCut

Always check the mowing head for signs of wear before installing new cutting blades.

! WARNING

If there are signs of serious wear, replace the complete mowing head.

The thermoplastic cutting blades are referred to as "blades" in the following.

The mowing head is supplied with illustrated instructions for replacing the blades. Keep the instructions for the mowing head in a safe place.

! WARNING

To reduce the risk of injury, always shut off the engine before installing the blades.

- Remove the mowing head.
- Replace blades as shown in the illustrated instructions.
- Mount the mowing head on the machine.

Inspections and Maintenance by Dealer

Maintenance Work

STIHL recommends that you have servicing and repair work carried out exclusively by an authorized STIHL servicing dealer.

Fuel Pickup Body in Tank

- Have the pickup body in the fuel tank replaced every year.

Spark Arrestor in Muffler and Spacer

See "Main Parts" for positions of spark arrestor and spacer.

- If the engine is down on power, have the spark arrestor in the muffler checked.
- Check spacer for damage.
- Have damaged spacer replaced immediately.

Maintenance and Care

The following intervals apply to normal operating conditions only. If your daily working time is longer or operating conditions are difficult (very dusty work area, etc.), shorten the specified intervals accordingly.		before starting work	after finishing work or daily	after each refueling stop	weekly	monthly	every 12 months	if problem	if damaged	as required
Complete machine	Visual inspection (condition, leaks)	X		X						
	Clean		X							
	Replace any damaged parts	X								
Control handle	Check operation	X		X						
Air filter	Visual inspection						X	X		
	Clean							X		X
	Replace								X	
Manual fuel pump (if fitted)	Check	X								
	Have repaired by servicing dealer ¹⁾								X	
Pickup body in fuel tank	Have checked by servicing dealer ¹⁾							X		
	Have replaced by servicing dealer ¹⁾						X		X	X
Fuel tank	Clean							X		X
Carburetor	Check idle adjustment – the cutting attachment must not rotate	X		X						
	Readjust idle									X
Spark plug	Readjust electrode gap							X		
	Replace after every 100 operating hours									
Cooling inlets	Visual inspection		X							
	Clean									X
Spark arrestor in muffler	Have checked by servicing dealer ¹⁾		X					X		
	Have cleaned or replaced by servicing dealer ¹⁾								X	X
Spacer	Check	X								
	Have replaced by servicing dealer ¹⁾	X						X		

The following intervals apply to normal operating conditions only. If your daily working time is longer or operating conditions are difficult (very dusty work area, etc.), shorten the specified intervals accordingly.		before starting work	after finishing work or daily	after each refueling stop	weekly	monthly	every 12 months	if problem	if damaged	as required
All accessible screws and nuts (not adjusting screws)	Retighten									X
Cutting attachment	Visual inspection	X		X						
	Replace								X	
	Check tightness	X		X						
Safety labels	Replace								X	
1) STIHL recommends an authorized STIHL servicing dealer.										

Main Parts

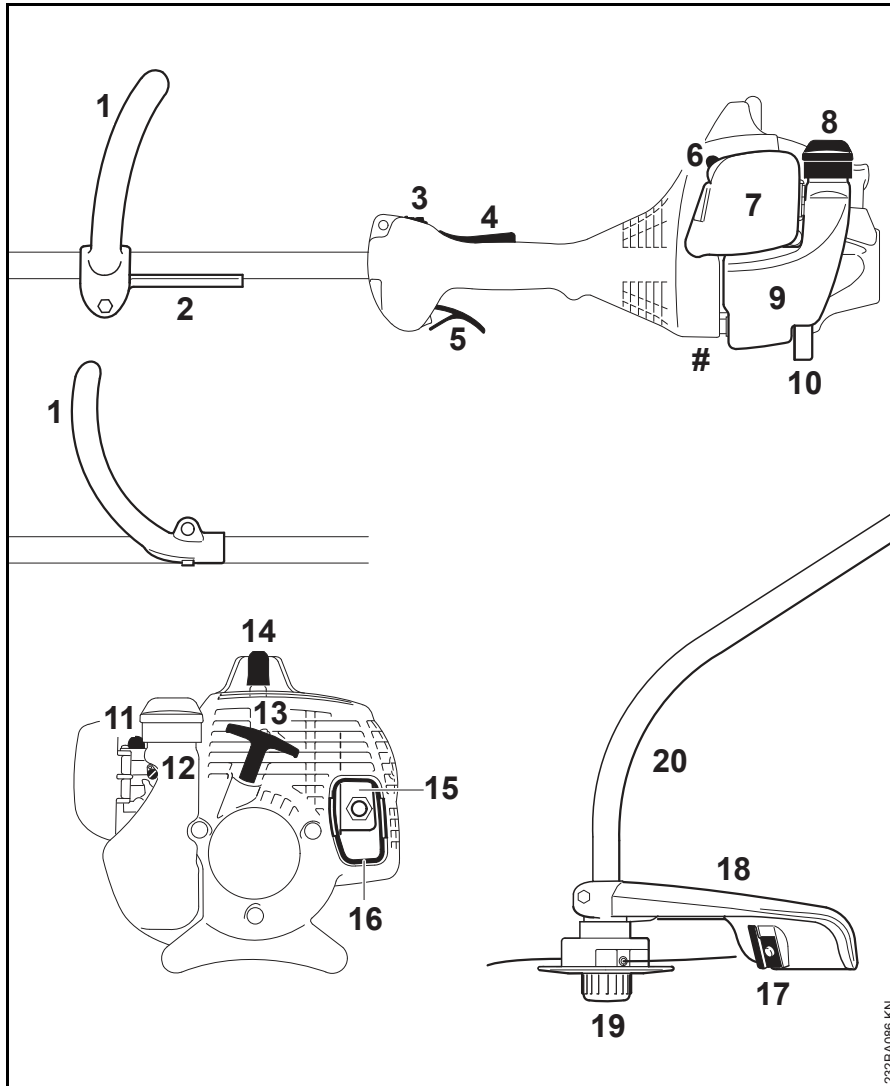

- 1 Loop handle
- 2 Spacer
- 3 Stop switch
- 4 Throttle trigger lockout
- 5 Throttle trigger
- 6 Choke lever
- 7 Air filter cover
- 8 Tank cap
- 9 Tank
- 10 Machine support
- 11 Manual fuel pump
- 12 Carburetor adjusting screws
- 13 Starter grip
- 14 Spark plug boot
- 15 Muffler with spark arrestor
- 16 Spacer
- 17 Line limiting blade
- 18 Deflector
- 19 Mowing head
- 20 Drive tube
- # Serial number

232BA086 KN

Specifications

Engine

Single cylinder two-stroke engine

Displacement:	27.2 cc
Bore:	34 mm
Stroke:	30 mm
Engine power to ISO 8893:	0.75 kW (1 HP) at 7,000 rpm
Idle speed:	2,800 rpm
Cut-off speed (rated):	9,500 rpm
Max. output shaft speed (cutting attachment):	9,500 rpm

Ignition System

Electronic magneto ignition

Spark plug (resistor type):	Bosch WSR 6 F, NGK BPMR 7 A
Electrode gap:	0.5 mm

Fuel System

All position diaphragm carburetor with integral fuel pump

Fuel tank capacity:	330 cc (0.33 l)
---------------------	-----------------

Weight

Dry, without cutting attachment and deflector

FS 45:	4.1 kg
FS 45 C with ErgoStart:	4.3 kg

FS 45, FS 45 C

Noise and Vibration Data

Noise and vibration data measurements include idling and rated maximum speed with the same duration of exposure.

For further details on compliance with Vibration Directive 2002/44/EC see www.stihl.com/vib.

Sound pressure level L_p to ISO 22868

FS 45:	94 dB(A)
FS 45 C:	94 dB(A)

Sound power level L_w to ISO 22868

FS 45:	104 dB(A)
FS 45 C:	104 dB(A)

Vibration measurement $a_{hv,eq}$ to ISO 22867

	Handle, left	Handle, right
FS 45:	7.5 m/s ²	6.0 m/s ²
FS 45 C:	7.5 m/s ²	6.0 m/s ²

The K-factor in accordance with Directive 2006/42/EC is 2.0 dB(A) for the sound pressure level and sound power level; the K-factor in accordance with Directive 2006/42/EC is 2.0 m/s² for the vibration level.

REACH

REACH is an EC regulation and stands for the Registration, Evaluation, Authorisation and Restriction of Chemical substances.

For information on compliance with the REACH regulation (EC) No. 1907/2006 see www.stihl.com/reach.

Exhaust Emissions

The CO₂ value measured in the EU type approval procedure is specified at www.stihl.com/co2.

The measured CO₂ value was determined on a representative engine in accordance with a standardized test procedure under laboratory conditions and does not represent either an explicit or implied guarantee of the performance of a specific engine.

The applicable exhaust emission requirements are fulfilled by the intended usage and maintenance described in this instruction manual. The type approval expires if the engine is modified in any way.

Maintenance and Repairs

Users of this machine may only carry out the maintenance and service work described in this user manual. All other repairs must be carried out by a servicing dealer.

STIHL recommends that you have servicing and repair work carried out exclusively by an authorized STIHL servicing dealer. STIHL dealers are regularly given the opportunity to attend training courses and are supplied with the necessary technical information.

When repairing the machine, only use replacement parts which have been approved by STIHL for this power tool or are technically identical. Only use high-quality replacement parts in order to avoid the risk of accidents and damage to the machine.

STIHL recommends the use of original STIHL replacement parts.

Original STIHL parts can be identified by the STIHL part number, the **STIHL** logo and the STIHL parts symbol  (the symbol may appear alone on small parts).

Disposal

Observe all country-specific waste disposal rules and regulations.

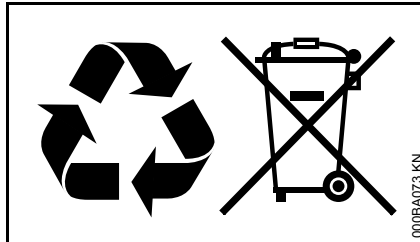

STIHL products must not be thrown in the garbage can. Take the product, accessories and packaging to an approved disposal site for environment-friendly recycling.

Contact your STIHL servicing dealer for the latest information on waste disposal.

EC Declaration of Conformity

ANDREAS STIHL AG & Co. KG
Badstr. 115
D-71336 Waiblingen

Germany

declare in exclusive responsibility that the product

Category:	Brushcutter
Make:	STIHL
Model:	FS 45
	FS 45 C
	FS 45 C-E

Serial identification:	4140
Displacement:	27.2 cc

conforms to the relevant provisions of Directives 2006/42/EC, 2014/30/EU and 2000/14/EC and has been developed and manufactured in compliance with the following standards in the versions valid on the date of production:

EN ISO 11806-1, EN 55012,
EN 61000-6-1

The measured and guaranteed sound power levels were determined according to Directive 2000/14/EC, Annex V, using the ISO 10884 standard.

Measured sound power level

107 dB(A)

Guaranteed sound power level

108 dB(A)

Technical documents deposited at:

ANDREAS STIHL AG & Co. KG
Produktzulassung (Product Licensing)

The year of manufacture and serial number are applied to the product.

Done at Waiblingen, 28.10.2016

ANDREAS STIHL AG & Co. KG

A handwritten signature in black ink that reads "Thomas Elsner". The signature is written in a cursive style with a large, looping 'T' and 'E'.

Thomas Elsner

Director Product Management and Services

The CE mark, consisting of the letters 'C' and 'E' in a bold, sans-serif font, positioned side-by-side.

0458-232-8321-E

AUS



www.stihl.com



0458-232-8321-E